

Basic Technical Data Sheet

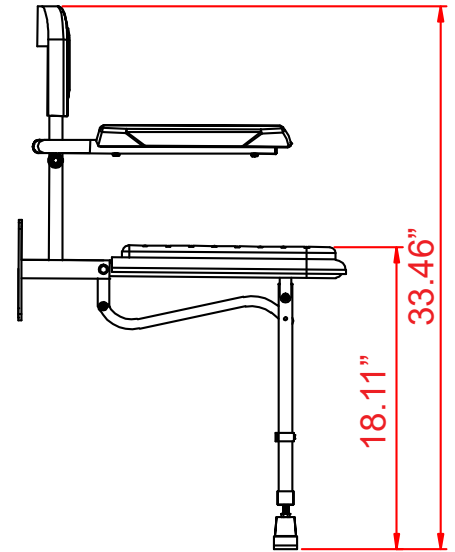
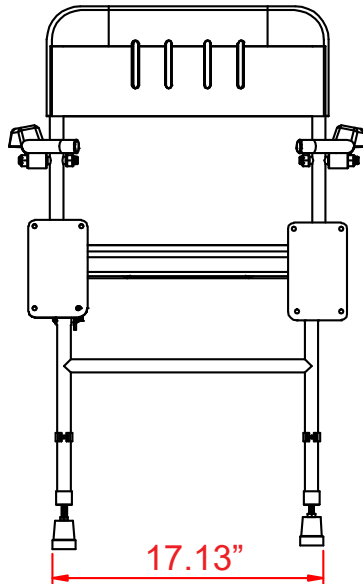
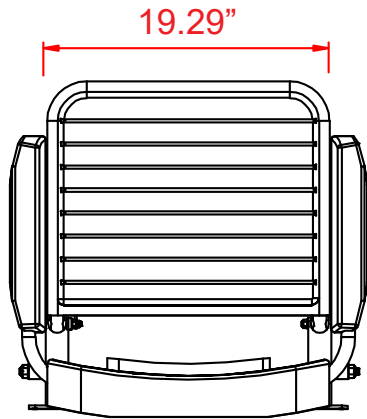

Product Code: **SFL2322PG**

Capacity: 418 lbs.

Dimensions (WxDxH): 23 1/2" x 21 1/2" x (18 1/4" - 24 1/4")

Additional Details: Rust-free aluminium lightweight frame with tough polymer coating, folds up when not in use. Wall fixed with adjustable legs. Padded seat and back.

Use and Installation Info

Use: Wall Installation

Cleaning: Clean using pure water and home disinfectants which have been sufficiently diluted in water. Do not use abrasive detergents and trichloroethylene, oxygenated water or acetone-based solvents.

Fasteners: Not included with the product

We suggest to use fasteners suitable to the wall characteristics on which the product will be installed.

This Shower Seat is height adjustable and the legs have fine adjustments to compensate for any variations in the shower tray. The integrated arms lift independently enabling safe and controlled transfer. The shower seat's frame is manufactured from rust free aluminium and the clip-on seat is injection moulded, making this shower seat an excellent solution for long term, maintenance free use. The seat and back are detachable and have drainage holes, which conform with MHRA standards.

All herein data are subject to continuous technical updating. The manufacturer reserves the right to make change and improvements to the products herein described without any previous notice.